

## Overview

GE intelligent modules are engineered to deliver high-performance features, superb reliability, and unbeatable quality. From control of ancillary equipment, to enhanced signaling functionality, these products add flexibility and powerful options to FireworX intelligent systems.

Designed expressly for small buildings, FireworX modules are addressable devices that are uniquely identified on the system by means of familiar rotary switches. Once registered, they share data and update status information that determines how the system behaves and how connected devices interact with one another.

Unique to FireworX modules is ground fault detection so precise that it actually pinpoints the specific module where the wiring problem has occurred. This saves hours of troubleshooting and wire tracing. And only FireworX provides this important feature!

The FireworX family of intelligent modules also offers contractors and installers simple setup and installation, while delivering options that take full advantage of intelligent fire alarm processing. With a microprocessor in each device, intelligence is distributed throughout the system so that command decisions are made instantly at the individual module, rather than bottlenecking at the control panel.

This not only speeds event processing, it also makes a more robust and reliable system – so robust, in fact, that when upgrading from a conventional panel to a FireworX intelligent system, you can usually use existing wiring – no twisted or shielded cable required!

## Standard Features

- **Class A-B Two-Wire Module**  
Acts as an interface between conventional two-wire smoke detectors and the FireworX control panel.
- **Analog Class A Single Input Module**  
Used to connect a normally open, alarm, supervisory, or monitor type dry contact initiating device circuit to the FireworX control panel.
- **Analog Dual Input Module**  
Connects two normally open, alarm, supervisory, or monitor type dry contact initiating device circuits to the FireworX control panel.
- **Analog Dual Input Waterflow, Supervisory Module**  
Used to connect normally open waterflow alarm and supervisory initiating device circuits to the FireworX control panel. For Class B circuit operation.
- **Analog SLC Fault Isolator Module**  
Protects a Class A SLC from total collapse due to wire-to-wire short circuits.
- **Analog NAC Module**  
Connects a supervised output circuit to a signal riser.
- **Analog Contact Relay Module**  
Provides one Form C dry relay contact and can be configured to provide polarity reversal of its output.
- **Analog Single Input Mini Module**  
Connects a normally open, alarm, supervisory, or monitor type dry contact initiating device circuit (IDC) to the FireworX control panel. For Class B circuit operation.

# Intelligent Input-Output Modules

Models: FX-2WIRE, FX-IDC1A, FX-IDC2B, FX-IDCWS, FX-ISO, FX-NAC, FX-RLY, FX-IDC1B

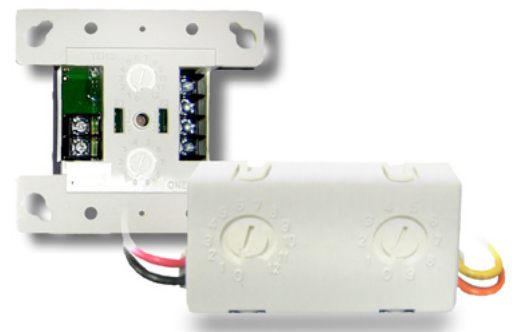

## Module Addressing

Use a screwdriver to adjust the two rotary switches on the front of the module. Set the TENS rotary switch (0 through 12) for the 10s digit and the ONES rotary switch for the 0 through 9 digit.

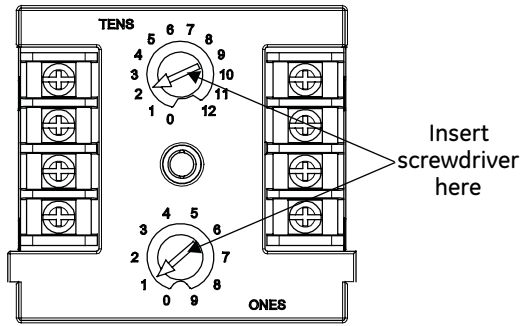

**Example:** device address 21, set TENS rotary switch to 2 and set the ONES rotary switch to 1.

Refer to the Specifications Table for available address numbers.

## LED operation

Modules provide a bicolor LED for status indication.

Flashing Green LED    **Normal**  
 Flashing Red LED      **Active**

## Installation

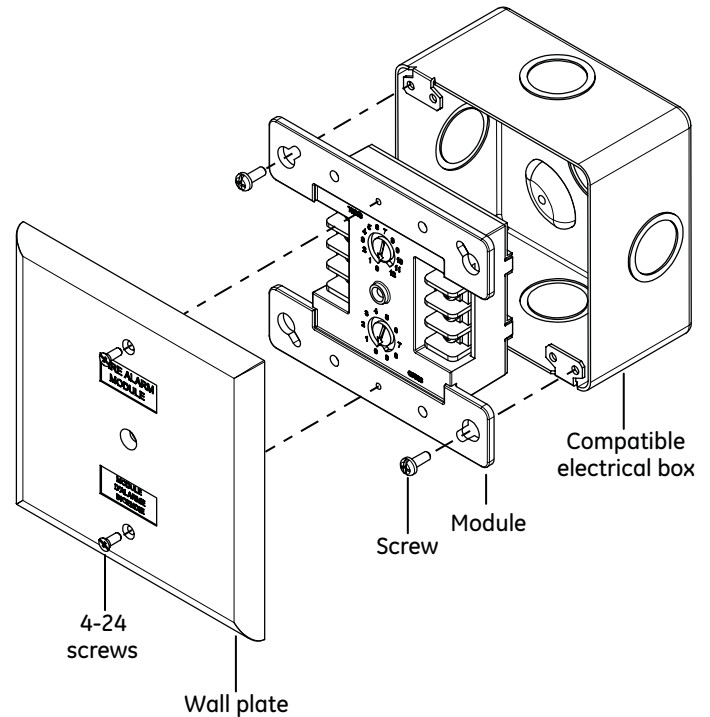

Mount in a North American 4 inch square x 2-1/2 in. (64 mm) deep 2 gang box or a standard 4 in. square box 1-1/2 in. (38 mm) deep.

## Class A Single Input Module

**FX-IDC1A**

The Class A Single Input Module is used to connect a normally open, alarm, supervisory, or monitor type dry contact initiating device circuit (IDC) to the FireworX control panel. The module is designed for Class A circuit operation.

The module's device address is set using the two rotary switches located on the front of the module. One device address is required.

The device can be preset for alarm or supervisory operation using the slide switch located on the front of the module. The module can also be configured for other device types through front panel programming or the configuration utility.

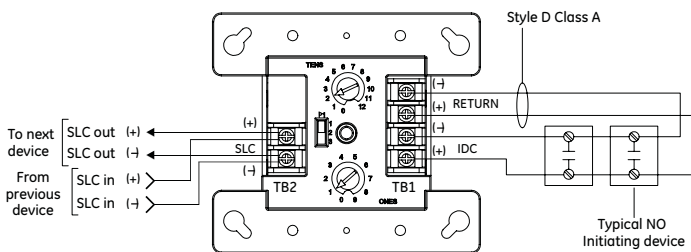

Communication line voltage	Maximum 20 V peak-to-peak
Current	
Standby	400 $\mu$ A
Activated	500 $\mu$ A
Ground fault impedance	10 k ohm
Operating environment	
Temperature	32 to 120°F (0 to 49°C)
Humidity	0 to 93% RH, noncondensing at 90°F (32°C)
Storage temperature range	-4 to 140°F (-20 to 60°C)
Compatible electrical boxes	North American 4 inch square x 2-1/2 in. (64 mm) deep 2 gang box Standard 4 in. square box 1-1/2 in. (38 mm) deep box
Wire size	12, 14, 16, or 18 AWG wire (2.5, 1.5, 1.0, or 0.75 sq. mm) (Sizes 16 and 18 AWG are preferred)
Device address	01 to 64 (64 point control panel) 01 to 127 (127 point control panel)
Initiating device circuit (IDC)	
Max. circuit resistance	50 $\Omega$ (25 $\Omega$ per wire)
Max. circuit capacitance	0.1 $\mu$ F

### Warning

This module will not operate without electrical power. As fires frequently cause power interruption, you should discuss further safeguards with your local fire protection specialist.

This module does not support conventional smoke detectors.

### Caution

Wire in accordance with NFPA 72 and CAN/ULC-S524. Be sure to observe the polarity of the wires as shown in the diagram.

## Class A-B Two-Wire Module

FX-2WIRE

The FX-2WIRE module interfaces between conventional two-wire smoke detectors and the FireworX control panel. It monitors the circuit and smoke detectors, and signals the control panel of any trouble or alarm conditions. The module also regulates and supervises the 24 VDC input power.

The FX-2WIRE is configured to operate as a two-wire alarm device that does not require alarm verification. It can be set for two-wire alarm verified operation through front panel programming or the configuration utility. When using the alarm verification feature of the control panel, do not mix normally open contact initiating devices with two-wire conventional smoke detectors.

This module recognizes the *CleanMe* signal from detectors that support this feature.

The device address is set using the two rotary switches located on the front of the module. One device address is required.

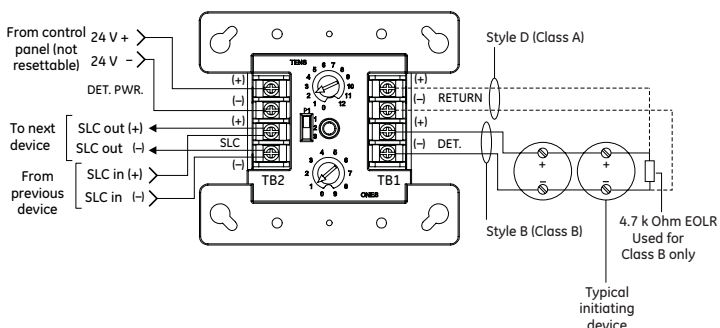

The FX-2WIRE can be set for Class B or Class A operation using the slide switch located on the front of the module.

**Note:** This module cannot be used on a device loop with isolator modules or isolator bases.

Communication line voltage	Maximum 20.6 V peak-to-peak
Current	Standby: 350 $\mu$ A. Activated: 350 $\mu$ A
Control panel input power	12.4 to 28.3 VDC (not resettable)
Smoke power current	Standby: 17 mA. Alarm: 58 mA
Smoke detector current	3 mA
UL compatibility ID	0.0
Ground fault impedance	5 k ohm
Operating environment	
Temperature	32 to 120°F (0 to 49°C)
Humidity	0 to 93% RH, noncondensing at 90°F (32°C)
Storage temperature	-4 to 140°F (-20 to 60°C)
Compatible electrical boxes	North American 4 inch square x 2-1/2 in. (64 mm) deep 2 gang box. Standard 4 in. square box 1-1/2 in. (38 mm) deep
Wire size	12, 14, 16, or 18 AWG wire (2.5, 1.5, 1.0, or 0.75 sq. mm) (Sizes 16 and 18 AWG are preferred)
Device address	01 to 64 (64 point control panel) 01 to 127 (127 point control panel)
Initiating device circuit	
EOL resistor value	4.7 k $\Omega$ , (P/N: EOL-4.7)
Max. circuit resistance	50 $\Omega$ (25 $\Omega$ per wire)
Max. circuit capacitance	0.1 $\mu$ F

## Dual Input Module

FX-IDC2B

The FX-IDC2B connects two normally open, alarm, supervisory, or monitor type dry contact initiating device circuits (IDCs) to the FireworX control panel. This module is designed for Class B circuit operation.

The device address is set using the two rotary switches located on the front of the module. Two consecutive addresses are required. The second address is automatically assigned one number higher than the value set on the rotary switches.

The FX-IDC2B can be preset for alarm or supervisory operation using the slide switch located on the front of the module. It can also be configured for other device types through front panel programming or the configuration utility.

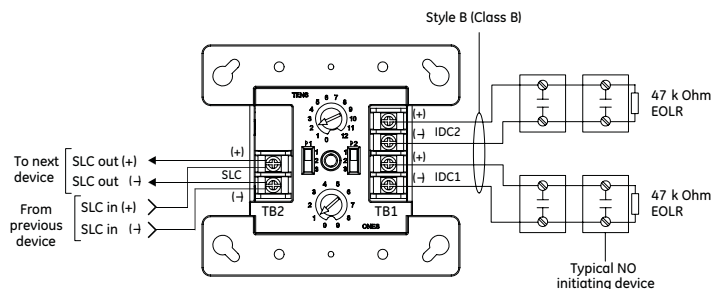

Communication line voltage	Maximum 20 V peak-to-peak
Current	
Standby	550 $\mu$ A
Activated	725 $\mu$ A
Ground fault impedance	10 k ohm
Operating environment	
Temperature	32 to 120°F (0 to 49°C)
Humidity	0 to 93% RH, noncondensing at 90°F (32°C)
Storage temperature range	-4 to 140°F (-20 to 60°C)
Compatible electrical boxes	North American 4 inch square x 2-1/2 in. (64 mm) deep 2 gang box Standard 4 in. square box 1-1/2 in. (38 mm) deep
Wire size	12, 14, 16, or 18 AWG wire (2.5, 1.5, 1.0, or 0.75 sq. mm) (Sizes 16 and 18 AWG are preferred)
Device address	01 to 63 (64 point control panel) 01 to 126 (127point control panel)
Initiating device circuit (IDC)	
EOL resistor value	47 k $\Omega$ , (P/N: EOL-47)
Max. circuit resistance	50 $\Omega$ (25 $\Omega$ per wire)
Max. circuit capacitance	0.1 $\mu$ F

## Dual Input Waterflow, Supervisory Module

FX-IDCWS

The FX-IDCWS connects normally open waterflow alarm and supervisory initiating device circuits (IDCs) to the FireworX control panel. The FX-IDCWS is designed for Class B circuit operation.

The device address is set using the two rotary switches located on the front of the module. Two consecutive addresses are required. The second address is automatically assigned one number higher than the value set on the rotary switches.

The FX-IDCWS can operate in the following modes:

### Waterflow

- Alarm latching delayed: Configures the module for use with only nonretarded waterflow alarm switches. When the NO input contact of an initiating device is closed, an alarm is sent to the control panel, which after a 16 second time delay, generates an alarm signal.

### Supervisory

- Supervisory active nonlatching US marketplace
- Supervisory active latching Canadian marketplace
- Nonlatching*: Configures the module for normally open dry

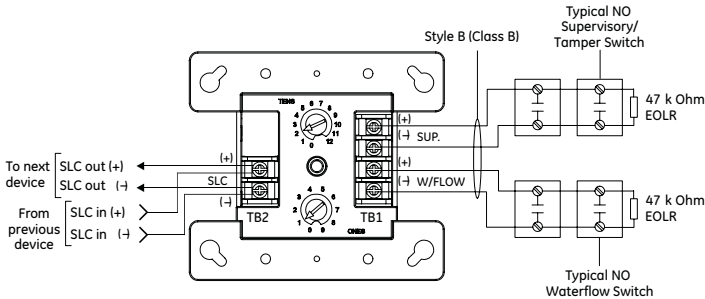

contact initiating devices. When the NO input contact of an initiating device is closed, a supervisory signal is sent to the control panel and the supervisory condition is not latched at the module.

- Latching*: Configures the module for normally open dry contact initiating devices. When the NO input contact of an initiating device is closed, a supervisory signal is sent to the control panel and the supervisory condition is not latched at the module.

Communication line voltage	Maximum 20 V peak-to-peak
Current	
Standby	550 $\mu$ A
Activated	725 $\mu$ A
Ground fault impedance	10 k ohm
Operating environment	
Temperature	32 to 120°F (0 to 49°C)
Humidity	0 to 93% RH
Storage temperature range	-4 to 140°F (-20 to 60°C)
Compatible electrical boxes	North American 4 inch square x 2-1/2 in. (64 mm) deep 2 gang box Standard 4 in. square box 1-1/2 in. (38 mm) deep
Wire size	12, 14, 16, or 18 AWG wire (2.5, 1.5, 1.0, or 0.75 sq. mm) (Sizes 16 and 18 AWG are preferred)
Device address	01 to 63 (64 point control panel) 01 to 126 (127 point control panel)
Initiating device circuit (IDC)	
EOL resistor value	47 k $\Omega$ , (P/N: EOL-47)
Max. circuit resistance	50 $\Omega$ (25 $\Omega$ per wire)
Max. circuit capacitance	0.1 $\mu$ F

## SLC Fault Isolator Module

FX-ISO

The FX-ISO protects a Class A SLC from total collapse due to wire-to-wire short circuits. The module monitors line voltages and opens the SLC when a short is detected. A short is isolated between the two modules located electrically closest to the short.

The device address is set using the two rotary switches located on the front of the module. One device address is required.

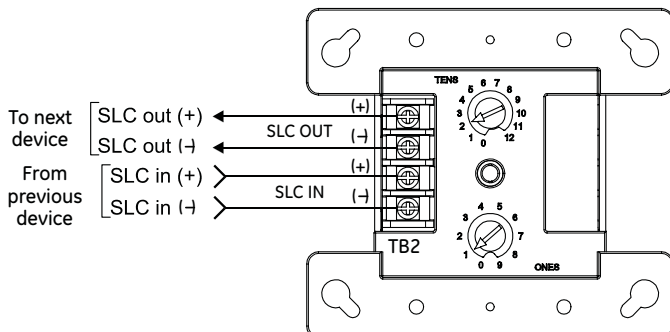

Communication line voltage	Maximum 20 V peak-to-peak
Current	
Standby	175 $\mu$ A
Activated	200 $\mu$ A
Ground fault impedance	10 k ohm
Maximum circuit resistance between isolators	6 ohm
Operating environment	
Temperature	32 to 120°F (0 to 49°C)
Humidity	0 to 93% RH, noncondensing at 90°F (32°C)
Storage temperature range	-4 to 140°F (-20 to 60°C)
Compatible electrical boxes	North American 4 inch square x 2-1/2 in. (64 mm) deep 2 gang box Standard 4 in. square box 1-1/2 in. (38 mm) deep
Wire size	12, 14, 16, or 18 AWG wire (2.5, 1.5, 1.0, or 0.75 sq. mm) (Sizes 16 and 18 AWG are preferred)
Module address	01 to 64 (64 point control panel) 01 to 127 (127 point control panel)

## NAC Module

FX-NAC

The FX-NAC connects a supervised output circuit to a signal riser. The output wiring is monitored for open and short circuits. A short circuit causes the module to inhibit the activation of the audible/visual signal circuit so the riser is not connected to the wiring fault. Upon command from the control panel, the module connects the output circuit to the riser input. The output circuit energizes a riser to operate polarized audible and visual signals. The module can be used for connection of a Class A or Class B (with EOL) output notification appliance circuit (NAC).

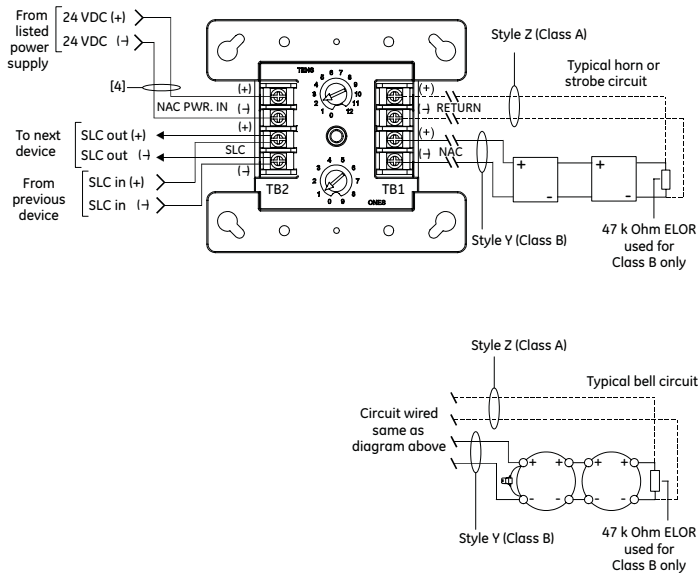

The FX-NAC is configured to operate as a Genesis Audible/Visual/Silence device type from the factory. It can also be configured for other device types through front panel programming or the configuration utility. Refer to the applicable control panel technical reference manual for a list of available device types.

**Genesis Audible/Visual/Silence:** Used with Genesis and Enhanced Integrity horns and strobes. Signals maintain synchronization per UL 1971. For Genesis devices, this configuration allows connected horns to be silenced while strobes on the same two-wire circuit continue to flash until the panel is reset.

Communication line voltage	Maximum 20 V peak-to-peak
Current	
Standby	350 $\mu$ A
Activated	200 $\mu$ A
Ground fault impedance	10 k ohm
Operating environment	
Temperature	32 to 120°F (0 to 49°C)
Humidity	0 to 93% RH, noncondensing at 90°F (32°C)
Output ratings	
Circuit current	24 VDC at 2 A max.
EOL resistor value	47 k $\Omega$ UL listed
Storage temperature range	-4 to 140°F (-20 to 60°C)
Compatible electrical boxes	North American 4 inch square x 2-1/2 in. (64 mm) deep 2 gang box Standard 4 in. square box 1-1/2 in. (38 mm) deep
Wire size	12, 14, 16, or 18 AWG wire (2.5, 1.5, 1.0, or 0.75 sq. mm) (Sizes 16 and 18 AWG are preferred)
Device address	01 to 64 (64 point control panel)
(one address required)	01 to 127 (127 point control panel)

## Contact Relay Module

FX-RLY

The FX-RLY provides one Form C dry relay contact. It can also be configured to provide polarity reversal of its output. The FX-RLY can be used to control external appliances or shut down equipment.

The FX-RLY is wired according to its operation. It is configured to operate as a relay nonsilence device type, and can function as either a control relay or polarity reversal relay, depending on how it is wired.

**Control relay function:** Provides one Form C dry relay contact.

**Polarity reversal relay function:** Provides polarity reversal of its output.

**Note:** Additional device types are available through front panel programming or the configuration utility. Refer to applicable control panel technical reference manual.

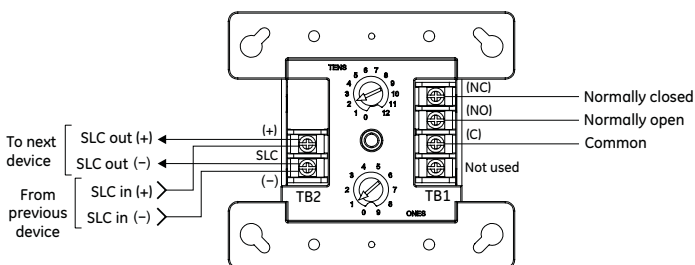

Communication line voltage	Maximum 20 V peak-to-peak
Current	
Standby	125 $\mu$ A
Activated	125 $\mu$ A
Contact ratings (pilot duty)	
30 VDC	2 A
125 VAC	0.5A resistive load 60 W or 62.5 VA max.
Relay type	Form C, programmable
Ground fault impedance	10 k ohm
Operating environment	
Temperature	32 to 120°F (0 to 49°C)
Humidity	0 to 93% RH, noncondensing at 90°F (32°C)
Storage temperature range	-4 to 140°F (-20 to 60°C)
Compatible electrical boxes	North American 4 inch square x 2-1/2 in. (64 mm) deep 1 gang box North American 4 inch square x 2-1/2 in. (64 mm) deep 2 gang box Standard 4 in. square box 1-1/2 in. (38 mm) deep box
Wire size	12, 14, 16, or 18 AWG wire (2.5, 1.5, 1.0, or 0.75 sq. mm) (Sizes 16 and 18 AWG are preferred)
Module address	01 to 64 (64 point control panel)
(one address required)	01 to 127 (127 point control panel)

U.S.  
T 888-GESECURITY  
F 503-691-7566

Canada  
T 519 376 2430  
F 519 376 7258

Asia  
T 852 2907 8108  
F 852 2142 5063

Latin America  
T 305 593 4301  
F 305 593 4300

www.gesecurity.com/fireworx

© 2009 General Electric Company  
All Rights Reserved

## Single Input Mini Module

FX-IDC1B

The FX-IDC1B connects a normally open, alarm, supervisory, or monitor type dry contact initiating device circuit (IDC) to the FireworX control panel. This module is for Class B circuit operation.

The device address is set using the two rotary switches located on the front of the module. One device address is required.

The module is configured to operate as an alarm latching device type from the factory. When the NO contact of an initiating device is closed, an alarm signal is sent to the control panel and the alarm condition is latched at the module.

Additional device types are available through front panel programming or the configuration utility. Refer to applicable control panel technical reference manual.

Communication line voltage	Maximum 20 V peak-to-peak
Current	
Standby	350 $\mu$ A
Activated	500 $\mu$ A
Ground fault impedance	10 k ohm
Operating environment	
Temperature	32 to 120°F (0 to 49°C)
Humidity	0 to 93% RH, noncondensing at 90°F (32°C)
Storage temperature range	-4 to 140°F (-20 to 60°C)
Wire size	12, 14, 16, or 18 AWG wire (2.5, 1.5, 1.0, or 0.75 sq. mm) (Sizes 16 and 18 AWG are preferred)
Device address (two addresses required)	01 to 64 (64 point control panel) 01 to 127 (127 point control panel)
Initiating device circuit (IDC)	
EOL resistor value	47 k $\Omega$ , (P/N: EOL-47)
Max. circuit resistance	50 $\Omega$ (25 $\Omega$ per wire)
Max. circuit capacitance	0.1 $\mu$ F

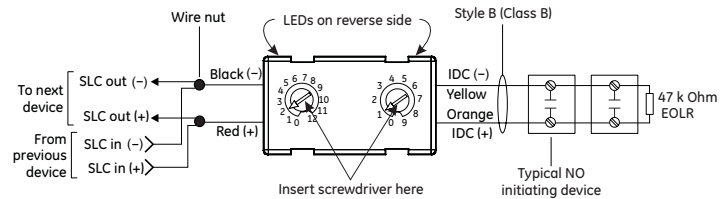

## Ordering Information

Model	Description	Ship Weight
FX-IDC1A	Analog Class A Single Input Module	0.50 lbs. (0.23 kg.)
FX-IDC1B	Analog Single Input Mini Module	0.34 lbs. (0.15 kg.)
FX-2WIRE*	Analog Class A-B Two-Wire Module	0.50 lbs. (0.23 kg.)
FX-IDC2B	Analog Dual Input Module	0.50 lbs. (0.23 kg.)
FX-2IDCWS	Analog Dual Input Waterflow-Supervisory Module	0.50 lbs. (0.23 kg.)
FX-NAC	Analog NAC Module	0.50 lbs. (0.23 kg.)
FX-RLY	Analog Contact Relay Module	0.50 lbs. (0.23 kg.)
FX-ISO	Analog SLC Fault Isolator Module	0.50 lbs. (0.23 kg.)

\*Available Q1, 2009