

## Overview

Genesis ceiling horn-strobes are small, compact, and attractive audible-visible emergency signaling devices. Protruding no more than 1.6" (41 mm) from the ceiling, Genesis horn-strobes blend with any decor.

Thanks to patented breakthrough technology, GE Security Genesis strobes do not require bulky specular reflectors and lenses. Instead, an exclusive cavity design conditions light to produce a highly controlled distribution pattern. Significant development efforts employing this new technology have given rise to a new benchmark in strobe performance – FullLight technology.

FullLight strobe technology produces a smooth light distribution pattern without the spikes and voids characteristic of specular reflectors. This ensures the entire coverage area receives consistent illumination from the strobe flash. As a result, Genesis strobes with FullLight technology go well beyond the minimum UL-required "cross" pattern.

Depending on the model, Genesis horn-strobes feature 15 to 95, or 95 to 177 candela output (see ordering information), which is selectable with a conveniently-located switch on the front of the device. The candela output setting is clearly visible even after final installation, yet it remains locked in place to prevent unauthorized movement after installation.

Genesis horn-strobes feature textured housings in architecturally neutral white or eye-catching fire alarm red. An ingenious iconographic symbol indicates the purpose of the device. This universal symbol is code-compliant and is easily recognized by all building occupants regardless of what language they speak. Models with "FIRE" markings are also available.

## Standard Features

- **Field configurable – no need to remove the device!**
  - 15/30/75/95 cd and 95/115/150/177 cd models available
  - Switch settings remain visible even after the unit is installed
  - Low/high dB settings
- **Unique low-profile design**
  - 30 per cent slimmer profile than comparable signals
  - No visible mounting screws
  - Available with white or red housings
- **Easy to install**
  - Fits all standard 4" square electrical boxes with plenty of room behind the signal for extra wire – no extension ring or trim plate needed
  - Pre-assembled with captive hardware – no loose pieces
  - #18 to #12 AWG terminals – ideal for long runs or existing wiring
- **Unparalleled performance**
  - Exclusive FullLight strobe technology produces the industry's most even light distribution
  - Single high-efficiency microprocessor controls both horn and strobe
  - Low current draw minimizes system overhead
  - Independent horn control provided over a single pair of wires
  - Highly regulated in-rush current allows the maximum number of strobes on a circuit
  - 100 dB peak – multiple frequency tone improves wall penetration

# Field Configurable Ceiling Horn-Strobes

## Genesis Series



## Application

Genesis strobes are UL 1971-listed for use indoors as ceiling-mounted public-mode notification appliances for the hearing impaired. Prevailing codes require strobes to be used where ambient noise conditions exceed 105 dBA (87dBA in Canada), where occupants use hearing protection, and in areas of public accommodation as defined in the *Americans with Disabilities Act* (see application notes – USA).

Combination horn-strobe signals must be installed in accordance with guidelines established for strobe devices.

### Strobes

Genesis strobes are UL 1971-listed for use indoors as wall-mounted public-mode notification appliances for the hearing impaired. Prevailing codes require strobes to be used where ambient noise conditions exceed specified levels, where occupants use hearing protection, and in areas of public accommodation. Consult with your Authority Having Jurisdiction for details.

All Genesis strobes exceed UL synchronization requirements (within 10 milliseconds other over a two-hour period) when used with a synchronization source. Synchronization is important in order to avoid epileptic sensitivity.

**NOTE:** The flash intensity of some visible signals may not be adequate to alert or waken occupants in the protected area. Research indicates that the intensity of strobe needed to awaken 90% of sleeping persons is approximately 100 cd. GE Security recommends that strobes in sleeping rooms be rated at at least 110 cd.

**WARNING:** These devices will not operate without electrical power. As fires frequently cause power interruptions, further safeguards such as backup power supplies may be required.

### Horns

Genesis horn output reaches as high as 99 dB (peak) and features a unique multiple frequency tone that results in excellent wall penetration and an unmistakable warning of danger. All models may be configured for either coded or non-coded signal circuits. They can also be set for low dB output with a jumper cut that reduces horn output by about 5 dB.

The suggested sound pressure level for each signaling zone used with alert or alarm signals is at least 15 dB above the average ambient sound level, or 5 dB above the maximum sound level having a duration of at least 60 seconds, whichever is greater, measured 5 feet (1.5 m) above the floor. The average ambient sound level is, A-weighted sound pressure measured over a 24-hour period.

Doubling the distance from the signal to the ear will theoretically result in a 6 dB reduction of the received sound pressure level. The actual effect depends on the acoustic properties of materials in the space. A 3 dBA difference represents a barely noticeable change in volume.

## Dimensions

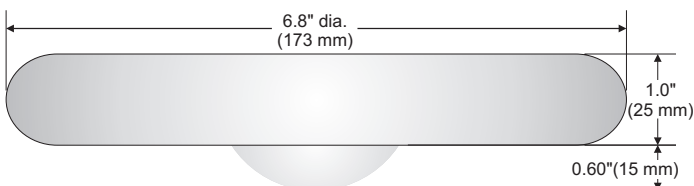

## Installation and Mounting

All models are intended for indoor wall or ceiling applications only. Horn-strobes mount to any flush North-American 4" square electrical box.

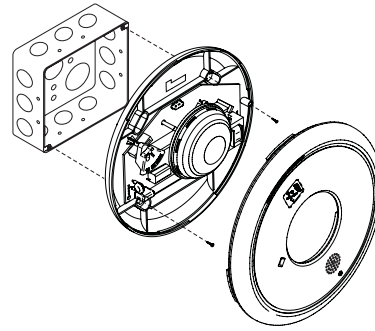

Genesis ceiling horn-strobes simply unlatch and twist to open. This gains access to mounting screws and the selectable candela switch. The shallow depth of Genesis devices leaves ample room behind the signal for extra wiring. Once installed with the cover in place, no mounting screws are visible.

GE Security recommends that these fire alarm horn-strobes always be installed in accordance with the latest recognized edition of national and local fire alarm codes.

### Field Configuration

Depending on the model, Genesis horn-strobes may be set for 15 to 95, or 95 to 177 candela output (see ordering information). The output setting is changed by simply opening the device and sliding the switch to the desired setting. The horn-strobe does not have to be removed to change the output setting. The setting remains visible through a small window on the front of the device after the cover is closed.

The horn-strobe comes factory set for high dB output. Low dB output may be selected by cutting a jumper on the circuit board. This reduces the output by about 5 dB.

## Wiring

Field wiring terminals accommodate #18 to #12 AWG (0.75 mm<sup>2</sup> to 2.5 mm<sup>2</sup>) wiring. Horn/strobes are interconnected with a single pair of wires as shown below.

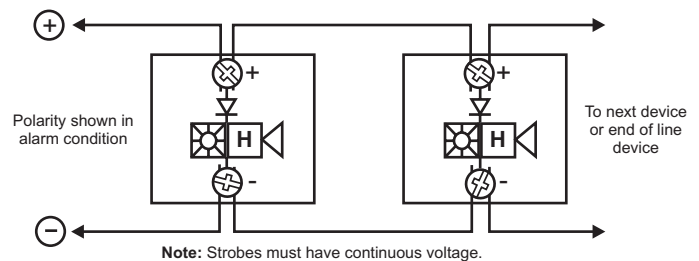

## Current Draw

### EGC-HDVM Temporal Horn-strobe: High dB Setting

UL Rating	15 cd RMS	30 cd RMS	75 cd RMS	95 cd RMS
16 Vdc	147	190	316	372
16 Vfwr	189	253	417	451

### EGC-HDVM Temporal Horn-strobe: High dB Setting

Typical Current	15 cd		30 cd		75 cd		95 cd	
	RMS	Mean	RMS	Mean	RMS	Mean	RMS	Mean
16 Vdc	111	95	152	143	281	276	333	328
20 Vdc	91	80	124	117	219	214	257	251
24 Vdc	80	71	108	101	185	180	212	207
33 Vdc	69	62	89	84	144	140	160	156
16 Vfwr	153	81	218	123	388	240	420	268
20 Vfwr	141	70	190	100	325	188	378	219
24 Vfwr	135	64	176	90	280	154	310	180
33 Vfwr	139	61	167	80	241	122	254	133

### EGC-HDVM Temporal Horn-strobe: Low dB Setting

Typical Current	15 cd		30 cd		75 cd		95 cd	
	RMS	Mean	RMS	Mean	RMS	Mean	RMS	Mean
16 Vdc	108	91	149	139	275	269	327	322
20 Vdc	87	75	120	113	214	209	250	245
24 Vdc	76	66	103	97	180	175	205	201
33 Vdc	64	57	85	80	138	135	153	150
16 Vfwr	141	76	204	118	384	239	418	265
20 Vfwr	127	65	176	95	312	181	371	214
24 Vfwr	118	60	162	82	262	149	301	171
33 Vfwr	127	56	155	73	229	118	249	129

### EGC-HDVMH High cd Temporal Horn-strobe: High dB Setting

95 cd RMS	115 cd RMS	150 cd RMS	177 cd RMS
341	399	506	570
487	578	670	711

### EGC-HDVMH High cd Temporal Horn-strobe: High dB Setting

95 cd		115 cd		150 cd		177 cd	
RMS	Mean	RMS	Mean	RMS	Mean	RMS	Mean
324	322	377	374	477	474	554	551
258	256	299	296	369	366	417	414
220	217	252	249	304	301	341	338
172	169	188	185	223	220	244	241
463	265	535	312	665	400	718	442
392	211	439	240	517	287	587	334
346	179	382	212	458	246	498	271
296	142	323	152	358	178	387	194

### EGC-HDVMH High cd Temporal Horn-strobe: Low dB Setting

95 cd		115 cd		150 cd		177 cd	
RMS	Mean	RMS	Mean	RMS	Mean	RMS	Mean
317	315	378	376	480	477	544	542
252	250	292	290	364	362	414	411
212	211	245	243	297	295	334	332
159	157	181	179	215	213	234	232
461	265	521	305	656	396	705	432
381	208	437	242	508	285	576	326
335	172	370	195	440	235	485	264
285	134	308	149	349	169	373	186

#### Notes and Comments

- Current values are shown in mA.
- UL Nameplate Rating can vary from Typical Current due to measurement methods and instruments used.
- GE Security recommends using the Typical Current for system design including NAC and Power Supply loading and voltage drop calculations.
- Use the Vdc RMS current ratings for filtered power supply and battery AH calculations. Use the Vfwr RMS current ratings for unfiltered power supply calculations.
- Fuses, circuit breakers and other overcurrent protection devices are typically rated for current in RMS values. Most of these devices operate based upon the heating affect of the current flowing through the device. The RMS current (not the mean current) determines the heating affect and therefore, the trip and hold threshold for those devices.
- Our industry has used 'mean' currents over the years. However, UL will direct the industry to use the 2004 RMS values in the future.

## dBA output

High dB Setting	UL464		Average	Peak
	Temporal	Steady	Temporal/ Steady	Temporal/ Steady
16 Vdc	79.8	83.2	90.6	93.6
24 Vdc	83.3	85.4	93.6	96.6
33 Vdc	85	87.8	95.7	98.7

Low dB Setting	UL464		Average	Peak
	Temporal	Steady	Temporal/ Steady	Temporal/ Steady
16 Vdc	75	79.3	86.3	88.7
24 Vdc	78	83	88.8	92.4
33 Vdc	80.9	85.9	91.8	95.1

#### Notes

- All values shown are dBA measured at 10 feet (3.01m);
- UL464 values measured in reverberation room;
- Average and Peak values are measured in anechoic chamber.

## Light output - (effective cd)

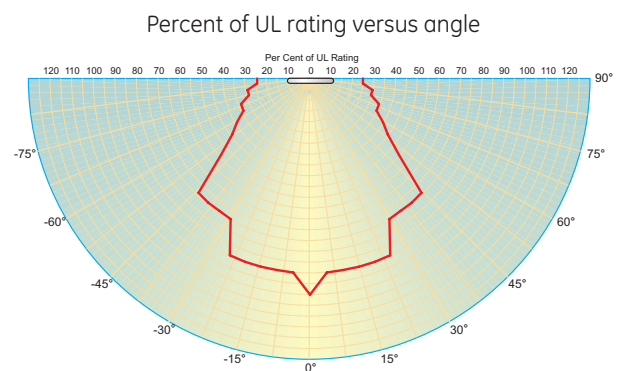

U.S.  
T 888-GESECURITY  
F 503-691-7566

Canada  
T 519 376 2430  
F 519 376 7258

Asia  
T 852 2907 8108  
F 852 2142 5063

Latin America  
T 305 593 4301  
F 305 593 4300

[www.gesecurity.com/fireworx](http://www.gesecurity.com/fireworx)

© 2009 General Electric Company  
All Rights Reserved.

Genesis Series is a trademark of GE Security.

## Specifications

Housing	Textured UV stabilized, color impregnated engineered plastic. Exceeds 94V-0 UL flammability rating. Red and white models available.
Lens	Optical grade polycarbonate (clear)
Mounting	North-American 4" square box, 2 1/8" (54 mm) deep (indoor wall or ceiling applications only).
Wire connections	Screw terminals: single input for both horn and strobe. #18 to #12 AWG (0.75 mm <sup>2</sup> to 2.5 mm <sup>2</sup> ) wire size
Operating environment	Indoor: 32-120°F (0-49°C) ambient temperature. 93% relative humidity
Agency listings/approvals	Meets or exceeds ULC-S541, year 2004 UL requirements for standards UL1638 and UL1971, and complies with UL1480. All horn-strobes comply with ADA Code of Federal Regulation Chapter 28 Part 36 Final Rule. CSFM, MEA, FM pending.
Operating voltage	EGC-HDVM series temporal-tone horn-strobes: non-coded, filtered 16-33 Vdc or unfiltered 16-33 Vdc FWR (or coded (audible NAC only) when used with optional EG1M Genesis Signal Master)
Strobe output rating	UL 1971, UL 1638, ULC S526: selectable 15/30/75/95 cd (EGC-HDVM) and 95/115/150/177 cd (EGC-HDVMH)
Strobe flash rate	EGC-HDVM series temporal-tone horn-strobes: one flash per second synchronized with optional EG1M Genesis Signal Master indefinitely within 10 milliseconds (or self-synchronized within 200 milliseconds over thirty minutes on a common circuit without EG1M Genesis Signal Master) Temporal setting (private mode only): synchronized to temporal output of horns on same circuit
Synchronization Sources	Module: EG1M-RM; Power Supplies: EBPS6A, EBPS10A; Panels: FX-10, FX-5, FX-3, FX-254, FX-64.
Horn pulse rate	EGC-HDVM series temporal-tone horn-strobes: temporal rate synchronized with optional EG1M Genesis Signal Master indefinitely within 10 milliseconds (or self-synchronized within 200 milliseconds over thirty minutes on a common circuit without EG1M Genesis Signal Master)
Temporal audible pattern	½ sec ON, ½ sec OFF, ½ sec ON, ½ sec OFF, ½ sec ON, 1½ sec OFF, then repeat cycle

## Ordering Information

Catalog Number	Housing Color	Marking	Description	Ship Wt. lbs (kg)
EGC-HDVM	White	None	Genesis Ceiling/Wall Horn-Strobe with selectable 15, 30, 75, or 95 cd output	0.82 (1.8)
EGCF-HDVM	White	"FIRE"		
EGCFR-HDVM	Red	"FIRE"		
EGC-HDVMH	White	None	Genesis Ceiling/Wall Horn-Strobe with selectable 95, 115, 150, or 177 cd output	
EGCF-HDVMH	White	"FIRE"		

### Accessories

EG1M-RM	Genesis Signal Master – Remote Mount (1-gang)	0.2 (0.1)
---------	---	-----------



White Field Configurable Ceiling Horn-Strobes may be ordered with or without optional 'FIRE' marking. Red Horn-Strobes come with 'FIRE' marking.