

Overview

The XAL-53 is an extremely rugged double-action fire alarm station suitable for hazardous locations. The device is activated by lifting the front cover and pulling down the ring. This two-step process prevents unintentional operation.

The station is reset by depressing the exposed shaft and returning the cover plate to its original position.

Standard Features

- Copper-free aluminum alloy construction
- ¾" NPT feed-through conduit openings
- Red textured powder epoxy paint finish provides high visibility
- Normally open and normally closed contacts

Application

XAL-53 fire alarm stations are suitable for areas that are hazardous due to the presence of flammable gases or vapors, combustible dusts, or easily-ignitable fibers or flyings. Install in petroleum refineries, chemical and petrochemical plants, storage areas, and other processing facilities where hazardous substances are handled or stored and in areas where emergency control of an alarm or signal circuit is required.

Hazardous location fire alarm station

XAL-53



U.S.
T 888-GESECURITY
F 503-691-7566

Canada
T 519 376 2430
F 519 376 7258

Asia
T 852 2907 8108
F 852 2142 5063

Latin America
T 305 593 4301
F 305 593 4300

www.gesecurity.com/fireworx

© 2009 General Electric Company
All Rights Reserved

Dimensions

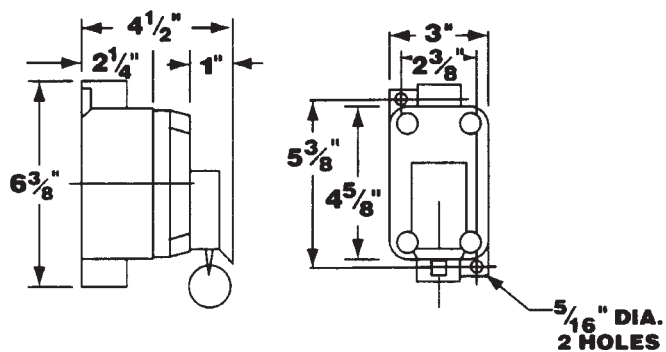

Hazardous classifications

- Class I, Div. 1 and 2, Groups C and D
- Class II, Div. 1 and 2, Groups E, F and G
- Class III
- NEMA Type 7, Groups C and D
- NEMA Type 9, Groups E, F and G

Ordering Information

Catalog Number	Description	Ship Wt., lb. (kg.)
XAL-53	Hazardous Location Fire Alarm Station	10 (4.5)



imagination at work