

Overview

GE weatherproof horns and temporal horn-strobes are specially designed for use with compatible life safety communication and control equipment to alert occupants of a life safety event. The horn emits a piercing low frequency sound that is easily heard above moderate ambient noise levels. The flash from its strobe can be noticed from almost any position in the room, corridor, or large open space.

The rugged plastic housing is made from durable and fire retardant, high impact plastic with a slightly textured surface. Its ingenious mounting plate firmly holds the device in place with a single screw. A separate trim plate is not required. Terminals accept up to #12 AWG (2.5mm²) wire for polarized connections.

Strobes are shipped with standard wall mount style "FIRE" lens markings. Where ceiling orientation, other languages, or different lens markings are required, GE Security offers optional LKW and LKC series Lens Marking Kits. These optional lens markings simply snap on to the strobe. Consult GE Security for availability of special lens markings.

GE weatherproof horns and horn-strobes are designed for 16 to 33 Vdc operation and must be connected to signal circuits that output a constant (not pulsed) voltage. A diode is used to allow full signal circuit supervision.

Standard Features

- **UL 1971-listed synchronizing strobe**
strobes synchronize to the latest UL 1971 requirements when used with a synchronization source.
- **Adjustable Audible Output**
Select temporal or continuous tones, and High setting for 98 dBA output or Low setting for 94 dBA sound output.
- **Approved for public and private mode applications**
UL 1971-listed as signaling devices for the hearing impaired and UL 1638-listed as protective visual signaling appliances.
- **Durable red or white Noryl front plate**
Ideal for outdoor, industrial or harsh environments.
- **Field changeable field markings**
Lens language or standard "FIRE" marking is easily changed with optional LKW and LKC series lens kits.
- **Easy Installation**
Flush mount to standard North American 4" square or two-gang box. GE's universal mounting plate allows it to be wired and then left hanging free for easy inspection and testing before it is fastened to the electrical box.

Weatherproof Horns and Horn-strobes

2447TH, 2452THS



Application

NOTE: The installation of visible and audible signals are subject to national and local standards, codes, and ordinances. Consult your Authority Having Jurisdiction for device installation requirements, application standards, and minimum performance specifications.

Horns

During installation, the horn is configured for steady or temporal tone signal and either low (94 dBA) or high (98 dBA) output. When temporal output is selected all horns on a common two-wire circuit are self-synchronized (see specifications). External control modules are not required for audible synchronization.

Suggested sound pressure level for each signaling zone used with alert or alarm signals is at least 15dB above the average ambient sound level, or 5dB above the maximum sound level having a duration of at least 60 seconds, whichever is greater, measured 5' (1.5m) above the floor. The average ambient sound level is the RMS, A-weighted sound pressure measured over a 24-hour period.

Doubling the distance from the signal to the ear will theoretically result in a 6 dB reduction of the received sound pressure level. The actual effect depends on the acoustic properties of materials in the space. A 3 dBA difference represents a barely noticeable change in volume.

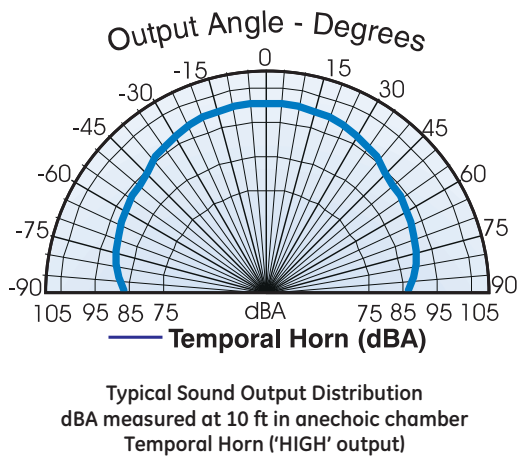

Strobes

GE Security strobes are UL 1971-listed for use indoors as wall-mounted public-mode notification appliances for the hearing impaired. Prevailing codes require strobes to be used where ambient noise conditions exceed specified levels, where occupants use hearing protection, and in areas of public accommodation. Consult with your Authority Having Jurisdiction for details.

2452 Series strobes exceed UL synchronization requirements (within 10 milliseconds other over a two-hour period) when used with a synchronization source. Synchronization is important in order to avoid epileptic sensitivity.

NOTE: The flash intensity of some visible signals may not be adequate to alert or waken occupants in the protected area. Research indicates that the intensity of strobe needed to awaken 90% of sleeping persons is approximately 100 cd. GE Security recommends that strobes in sleeping rooms be rated at at least 110 cd.

WARNING: These devices will not operate without electrical power. As fires frequently cause power interruptions, further safeguards such as backup power supplies may be required.

Typical Wiring

The strobe must be connected to signal circuits which output a constant (not pulsed) voltage. The horn can be connected to continuous voltage circuits.

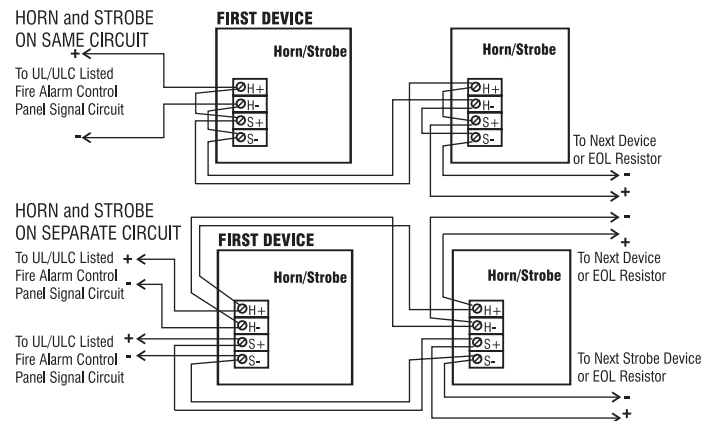

Light Output Patterns

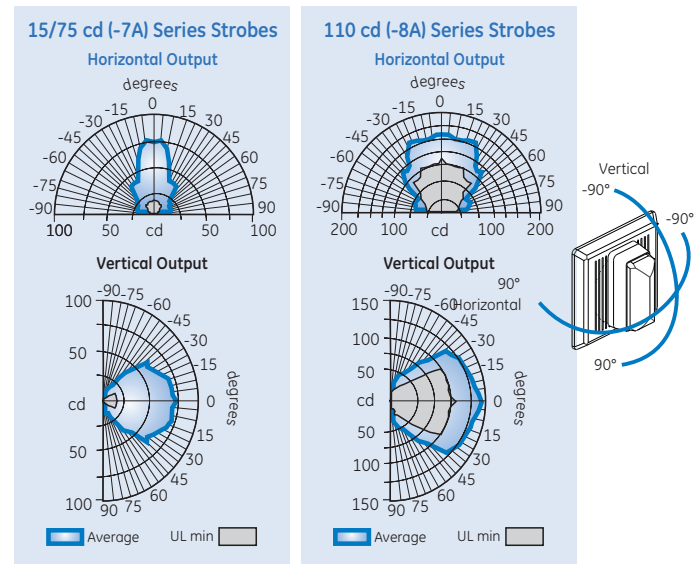

Strobe Operating Current (RMS)

Vdc: Volts direct current, regulated and filtered

Vfwr: Volts full wave rectified

UL Rating	15/75 cd	110 cd
16 Vdc	150	329
16 Vfwr	210	420

Current Draw Notes and Comments

- Current values are shown in mA.
- UL Nameplate Rating can vary from Typical Current due to measurement methods and instruments used.
- GE Security recommends using the Typical Current for system design including NAC and Power Supply loading and voltage drop calculations.
- Use the 16 Vdc RMS current ratings for filtered power supply and battery AH calculations. Use the 16 Vfwr RMS current ratings for unfiltered power supply calculations.
- Fuses, circuit breakers and other overcurrent protection devices are typically rated for current in RMS values. Most of these devices operate based upon the heating effect of the current flowing through the device. The RMS current determines the heating affect and therefore, the trip and hold threshold for those devices.

Typical Current	15/75 cd	110 cd
24 Vdc	90	180
24 Vfwr	128	260

dBA Output

Horn-strobes						
	UL464		Average - anechoic		Peak - anechoic	
	Temporal	Steady	Temporal	Steady	Temporal	Steady
High dB Output	79.0	85.0	97.0	97.0	102.0	102.0
Low dB Output	75.0	79.0	93.0	93.0	98.0	98.0

Horns						
	UL464		Average - anechoic		Peak - anechoic	
	Temporal	Steady	Temporal	Steady	Temporal	Steady
High dB Output	82.0	85.0	98.0	98.0	104.0	104.0
Low dB Output	75.0	82.0	94.0	94.0	99.0	99.0

dBA Output Notes and Comments

- All values shown are dBA measured at 10 feet (3.01m).
- UL1480 values measured in reverberation room.
- Average values are measured in anechoic chamber.

Specifications

Rated Strobe Output - candela (cd)	2447TH	2452THS-15/75	2452THS-110
UL 1638	N/A (horn only)	75 cd	110 cd
UL 1971		15 cd wall 15 cd ceiling	110 cd wall 60 cd ceiling
ULC S526		75 cd	120 cd
Standalone Synchronization Characteristics (note 2)	Strobe flash at 1 per second within 200 milliseconds on common circuit Horn pulses at temporal rate within 200 milliseconds on common circuit		
Operating Volts	Strobe: 16-33 Vdc or Vfwr Continuous Horn: 16-33 Vdc or Vfwr Continuous		
Horn Output (note 1)	Anechoic: High Setting - 104 dBA (peak)/98 dBA (avg); Low Setting - 99 dBA (peak)/94 dBA (avg) Reverberent: High Setting - 85 dBA (continuous)/82 dBA (temporal); Low Setting - 82 dBA (continuous)/75 dBA (temporal)		
Horn Current	High Output: 40 mA @ 24 Vdc; 55mA @ 24 Vrms FWR Low Output: 20 mA @ 24 Vdc; 28 mA @ 24 Vrms FWR		
Strobe Flash Synchronization	Synchronized at one flash per second. External control module necessary to meet UL 1971 synchronization requirements of 10 milliseconds over a two-hour period.		
Synchronization Sources	Module: EG1M-RM; Power Supplies: EBPS6A, EBPS10A; Panels: FX-10, FX-5, FX-3, FX-254, FX-64		
Strobe Marking	Supplied with LKW-1 "FIRE" red letters, vertical both sides (Wall Mount) - see LKW and LKC series for ceiling style and optional markings.		
Flash Tube Enclosure	Clear LEXAN with white marking sleeve		
Housing	Textured, color impregnated engineered plastics - exceeds 94V-0 UL flammability rating		
Wire Connections	Terminals - separate, polarized inputs for Horn & Strobe, #12 AWG (2.5mm ²) maximum		
INDOOR Operating Environment	32-120° F (0-49° C) ambient temperature. 93% relative humidity @ 40° C		
OUTDOOR Operating Environment (must use weatherproof box)	98% relative humidity @ 40° C; -31-150° F (-35-66° C) ambient temperature (2452THS-15/75: rated at 17.7 cd @ -35° C per UL/@ -40° C per ULC) (2452THS-110: rated at 70.7 cd @ -35° C per UL/@ -40° C per ULC)		
Mounting - INDOOR	Flush: North-American 2-gang box, 3" high x 4" wide x 2¾" (69 mm) minimum		
Mounting - OUTDOOR	Surface: 2459-WPB Weatherproof Box		
Agency Listings	UL 1971, UL 1638, UL 464, ULC S526, ULC S525, MEA, CSFM, FM, CE (All models comply with ADA Code of Federal Regulation Chapter 28 Part 36 Final Rule)		

Note 1 - Measured at 10 ft (3m) @ 24 Vdc. Subtract 3 dBA for models with strobes. **Note 2** - Temporal audible pattern is defined as: ½ sec ON, ½ sec OFF, ½ sec ON, ½ sec OFF, ½ sec ON, 1½ sec OFF, then repeat cycle. The audible will not be affected by signal silence operation when on the same two wire circuit with GE horn strobes.

U.S.
T 888-GESECURITY
F 503-691-7566

Canada
T 519 376 2430
F 519 376 7258

Asia
T 852 2907 8108
F 852 2142 5063

Latin America
T 305 593 4301
F 305 593 4300

www.gesecurity.com/fireworx

© 2009 General Electric Company
All Rights Reserved

Installation and Mounting

All models fit to a standard flush mounted, North-American two-gang electrical box, 2¾ inch (69 mm) minimum. Optional flush trims are not required. For surface mount, use GE Security's custom indoor and outdoor surface boxes painted in color-matched red or white epoxy. GE Security recommends that fire alarm horn/strobes always be installed in accordance with the latest recognized edition of national and local fire alarm codes.

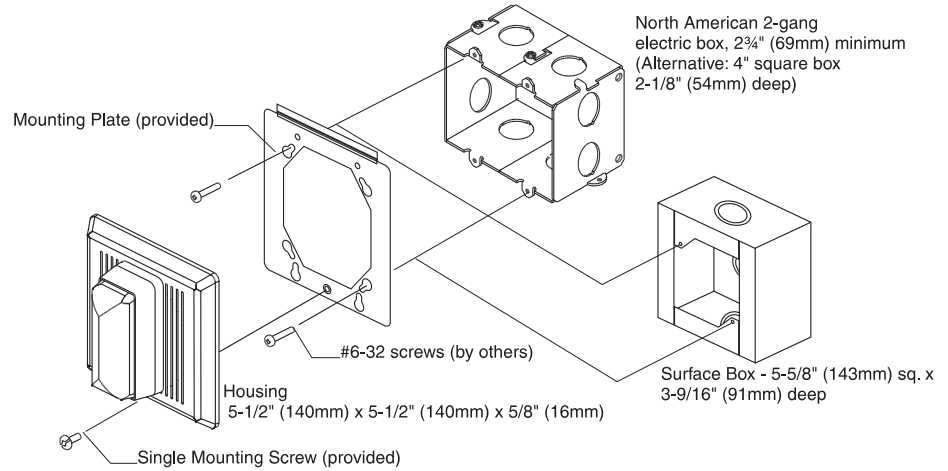

Ordering Information

Catalog Number	Description	Ship Wt., lb. (kg)
Temporal Horns (order weatherproof mounting box separately)		
2447TH-R	Temporal Horn, Red	1.7 (0.8)
2447TH-W	Temporal Horn, White	
Temporal Horn-Strobes (order weatherproof mounting box separately)		
2452THS-15/75-R	Temporal Horn-Strobe, 15/75cd, Red	2.0 (0.9)
2452THS-110-R	Temporal Horn-Strobe, 110cd, Red	
Weatherproof mounting boxes		
2459-WPB-R	Weatherproof Box, Red, for Horn-Strobes	
2459-WPB-W	Weatherproof Box, White, for Horn-Strobes	
Lens Marking Kits (see note 1)		
LKW-1	"FIRE", Wall Orientation (supplied)	0.1 (0.05)
LKW-1R	"FIRE", Wall Orientation, RED	
LKW-2	"FEU", Wall Orientation	
LKW-3	"FIRE/FEU", Wall Orientation	
LKW-4	"SMOKE", Wall Orientation	
LKW-5	"HALON", Wall Orientation	
LKW-6	"CO2", Wall Orientation	
LKW-7	"EMERGENCY", Wall Orientation	
LKW-8	"ALARM", Wall Orientation	
LKW-9	"FUEGO", Wall Orientation	
<i>Change "W" to "C" for CEILING mount. (e.g. LKC-1)</i>		



imagination at work